

PROJECTION DISTANCE AND SCREEN SIZE

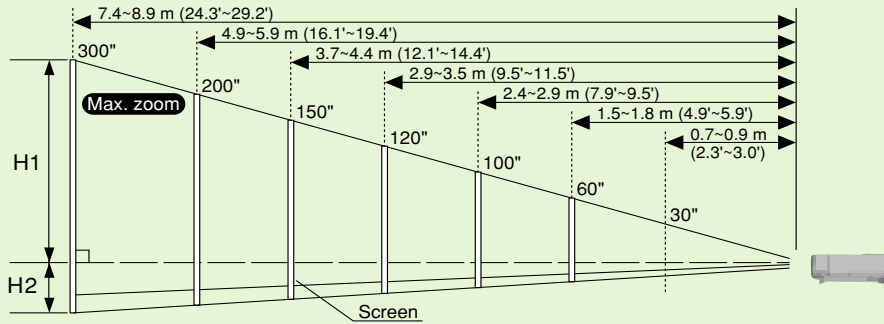

Screen size	300 inches	200 inches	150 inches	120 inches	100 inches	60 inches	30 inches
W x H (mm/inch)	6,096 x 4,572 240" x 180"	4,064 x 3,048 160" x 120"	3,048 x 2,286 120" x 90"	2,438 x 1,828 96" x 72"	2,032 x 1,524 80" x 60"	1,219 x 914 48" x 36"	610 x 457 24" x 18"
Height H1 (mm/inch)	3,920 154.3"	2,610 102.8"	1,960 77.2"	1,577 62.1"	1,310 51.6"	780 30.7"	390 15.4"
Height H2 (mm/inch)	650 25.6"	440 17.3"	330 13.0"	260 10.2"	220 8.7"	130 5.1"	70 2.8"

PROFILE

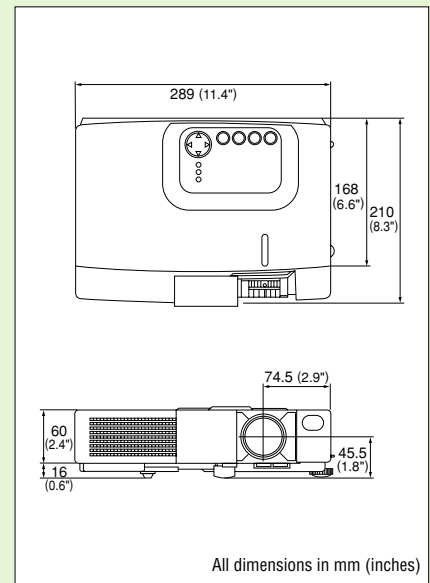

SPECIFICATIONS

Model	EDP-S10
Power source	AC 100 – 120V, AC 220 – 240V
Power consumption	200W
LCD panel	0.7-inch polysilicon active matrix TFT x 3
Number of pixels	480,000 pixels [600 (V) x 800 (H)]
Resolution	SVGA (800 x 600), VGA (640 x 480), compressed XGA (1,024 x 768)
Light source	130W UHB lamp
Brightness	800 ANSI lumens
Lens	Manual 1:1.2
Contrast ratio	200:1
Image size	30 to 300 inches diagonal
Projection distance	0.7 m to 8.9 m (2.3' to 29.2')
Computer compatibility	VGA, SVGA, XGA (compressed), Mac 13-inch, Mac 16-inch
Video compatibility	NTSC, NTSC 4.43, PAL, PAL60, SECAM, M-PAL, N-PAL
Speakers	1W x 1
In/out terminals	Computer x 1 (D-sub 15-pin), video input x 2 [composite (RCA) x 1, S-Video (4-pin DIN)], audio input x 1 [stereo mini (RGB/video)]
Fan noise	34dB
Operating temperature	0 to 35°C (32 to 95°F)
Dimensions (W x H x D)	289 x 60 x 210 mm (11.4" x 2.4" x 8.3")
Weight	2.4 kg (5.3 lbs)
Supplied accessories	Remote control unit, power cord, RGB cable, Mac adaptor, video cable, audio cable, 8-language owner's manual, soft carrying case
Optional accessories	Remote mouse unit, full-function remote control unit, RS-232C cable

XGA Desk-Top Presenter



- Direct connection to an LCD data projector for instant on-site presentations of printed and 3D material
- True XGA resolution
- Folds into a super-compact unit for easy portability
- Analog RGB output for connecting to a data projector or a PC monitor (cannot be used with an interlaced video monitor)

Design and specifications are subject to change without prior notice. Dimensions and weight are approximate.

ELMO® ELMO CO., LTD.

6-14, Meizen-cho, Mizuho-ku,
Nagoya, 467-8567 Japan
E-mail: foreign-div@elmo.co.jp

Distributed by

Additional technical information is available from any of the following subsidiary companies;

ELMO Mfg. Corp.

1478 Old Country Road,
Plainview, NY 11803-5034, U.S.A.
Tel. 516-501-1400
Fax. 516-501-0429
E-mail: elmo@elmousa.com
Web: <http://www.elmousa.com>

ELMO Canada Mfg. Corp.

44 West Drive, Brampton,
Ontario, L6T 3T6, Canada
Tel. 905-453-7880
Fax. 905-453-2391
E-mail: info@elmocanada.com
Web: <http://www.elmocanada.com>

ELMO (Europe) G.m.b.H.

Neanderstr. 18, 40233
Düsseldorf, Germany
Tel. 0211-376051-53
Fax. 0211-376630
E-mail: elmoeurope@AOL.com
Web: <http://www.elmo.de/>